

50mm DIAMETER STRUCTURAL HEAD

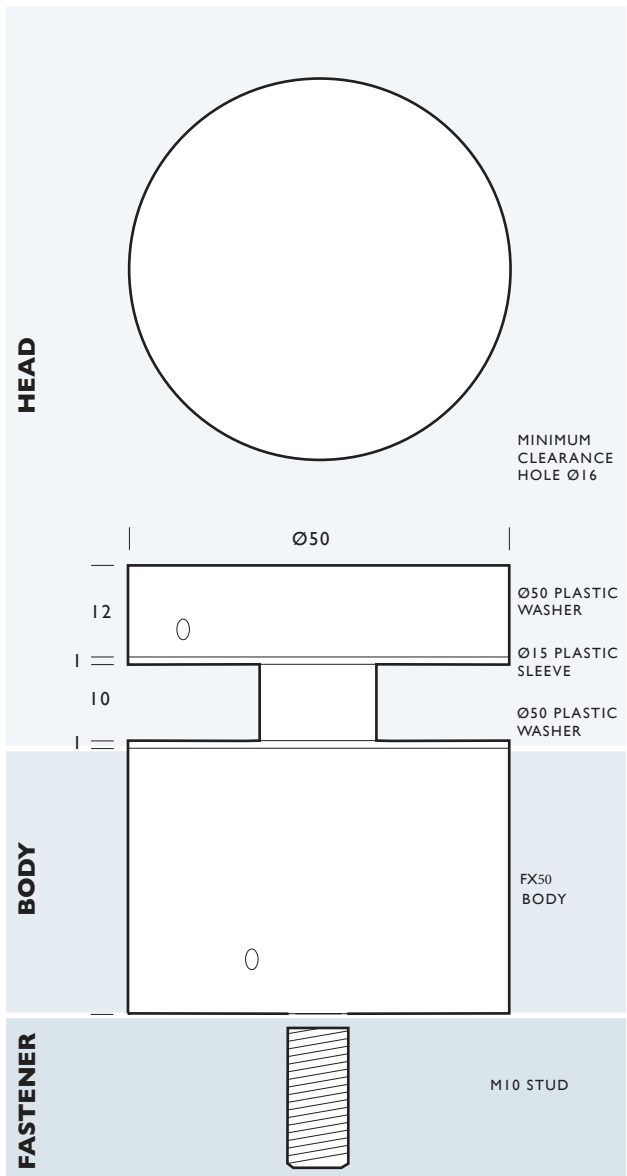

HEAD: HEADS CAN ALSO BE CUSTOM MADE TO 10mm HIGH

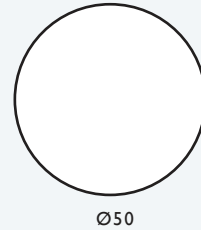

FX50 HEAD PACK:

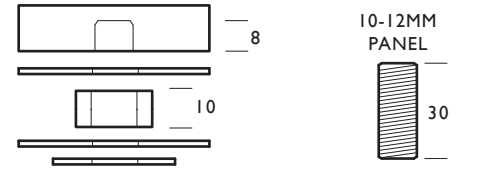

BODIES: Ø32 + Ø50

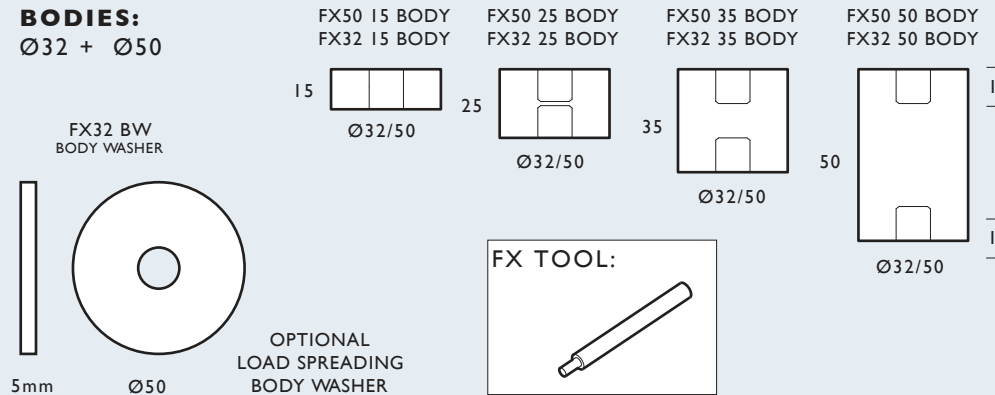

FASTENERS M10: *fasteners supplied with M10 stud*

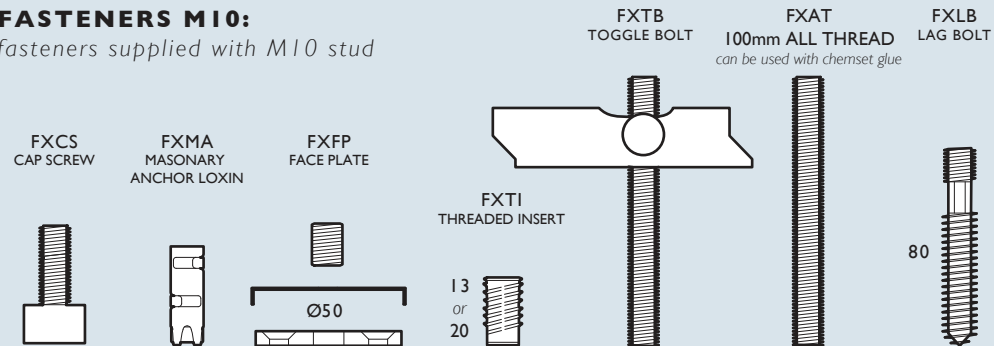

FX50 STANDARD

MATERIAL:

316 Grade Stainless Steel

PANEL THICKNESS:

Head Pack 10 - 12mm

Optional studs available:

16mm, 20mm, 25mm, 30mm, 35mm, 40mm, 50mm

MINIMUM CLEARANCE HOLE:

With isolating sleeve Ø16

Without isolating sleeve Ø10.5

THREAD:

Head: M10 x 8mm

Fastener: M10 x 12mm

FINISH:

Satin Stainless Steel

LOCATION:

Interior and exterior applications

PRODUCT COMPLIANCY:

As FIX Systems are not certified engineers, it is the buyer's responsibility to ensure that the application of all FIX products is suitable for its intended use and that it is compliant with relevant safety standards.

